

SEWER FORCE MAIN @ ROAD INTERSECTIONS  
DETAIL S-14

MINIMUM DESIGN & CONSTRUCTION STANDARDS FOR GREASE TRAP AND OIL/SAND SEPARATOR

A. GENERAL

1. USABLE LIQUID CAPACITY OF TANK MUST NOT BE LESS THAN 1000 GALLONS. FOR OIL/SAND SEPARATOR REFER TO SPECIFICATIONS FOR SIZING CALCULATIONS.
2. THE TANK LENGTH MUST BE AT LEAST TWO (2) BUT NOT MORE THAN THREE (3) TIMES THE WIDTH.
3. THE UNIFORM LIQUID DEPTH MUST NOT BE LESS THAN FOUR (4) FEET.
4. AT LEAST ONE (1) FOOT OF FREEBOARD MUST BE PROVIDED.
5. VIBRATION METHODS MUST BE EMPLOYED TO PREVENT VOIDS.
6. WALL AND BOTTOM THICKNESS SHALL BE AS REQUIRED FOR STRUCTURAL STABILITY, BUT NOT LESS THAN FOUR (4) INCHES IN THICKNESS.
7. INLET MUST ENTER TANK A MINIMUM OF THREE (3) INCHES ABOVE THE LIQUID LEVEL.
8. INLET TEE SHALL EXTEND SIXTEEN (16) INCHES BELOW LIQUID LEVEL.
9. OUTLET TEE SHALL EXTEND DOWN TO SIX (6) INCHES ABOVE THE BOTTOM OF THE GREASE TRAP.
10. ACCESS OPENINGS MUST BE LOCATED ABOVE INLET AND OUTLET DEVICES, AND LIDS SHALL BE EQUIPPED WITH LIFT RINGS.
11. TANKS LOCATED IN TRAFFIC AREAS MUST BE DESIGNED TO A HS-20 LOADING.

B. TYPE OF REINFORCEMENT

1. TANK WALLS AND BOTTOM - 6 X 6, 10 GAUGE WIRE MESH.
2. TANK LIDS (TOPS) - NUMBER 3 RODS, 6 INCHES ON CENTER EACH WAY, OR 6 X 6, 10 GAUGE WIRE MESH PLUS ONE NUMBER 3 ROD PER LINEAR FOOT OF TANK TOP.
3. ALL REINFORCING WIRE AND RODS SHOULD BE COVERED BY AT LEAST 1/2 INCH OF CONCRETE.

C. CONCRETE

1. STRENGTH - MIX SHOULD BE CALCULATED TO YIELD A MINIMUM 28 DAY COMPRESSIVE STRENGTH OF 4,000 PSI.
2. TYPES OF AGGREGATE
  - A. SAND - FINE UP TO 1/4 INCH
  - B. GRANITE DUST OR FINE SCREENINGS FROM CRUSHER OPERATION MAY BE USED IN LIEU OF SAND
  - C. GRAVEL OR CRUSHED STONE - SHOULD NOT EXCEED 1/3 OF WALL THICKNESS, I.E. FOR 2 1/2" WALL THICKNESS, AGGREGATE SHOULD NOT EXCEED A SIZE OF 3/4"
3. PORTION AND QUALITY CONTROL - EVERY MANUFACTURER SHOULD HAVE PORTION CONTROL AND SUCH OTHER EQUIPMENT AND CAPABILITIES NECESSARY TO MAINTAIN CONSTANT MIX RATIOS AND SYSTEMATIC INSPECTION OF FINISHED PRODUCTS TO RULE OUT UNSUITABLE SPECIMENS.

D. TANK IDENTIFICATION

- AN IDENTIFYING SEAL BEARING THE FOLLOWING ITEMS MUST BE CAST OR STAMPED INTO THE OUTLET END, WITHIN SIX (6) INCHES OF THE TOP:
1. MANUFACTURER
  2. MANUFACTURER'S ADDRESS
  3. LIQUID CAPACITY OF TANK
  4. DESIGN LOADING

F. GUARANTEE

ALL TANKS MUST BE GUARANTEED IN WRITING FOR TWO (2) YEARS AGAINST FAILURE DUE TO POOR WORKMANSHIP AND MATERIALS OF THE MANUFACTURER.

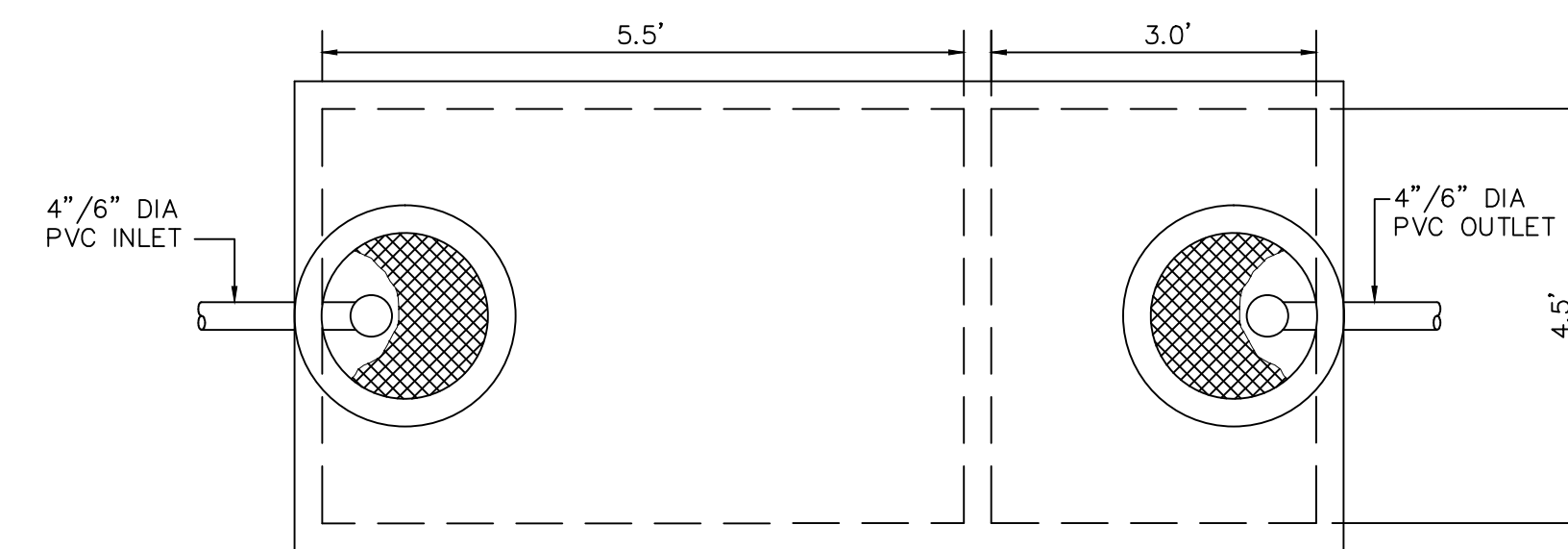

PLAN

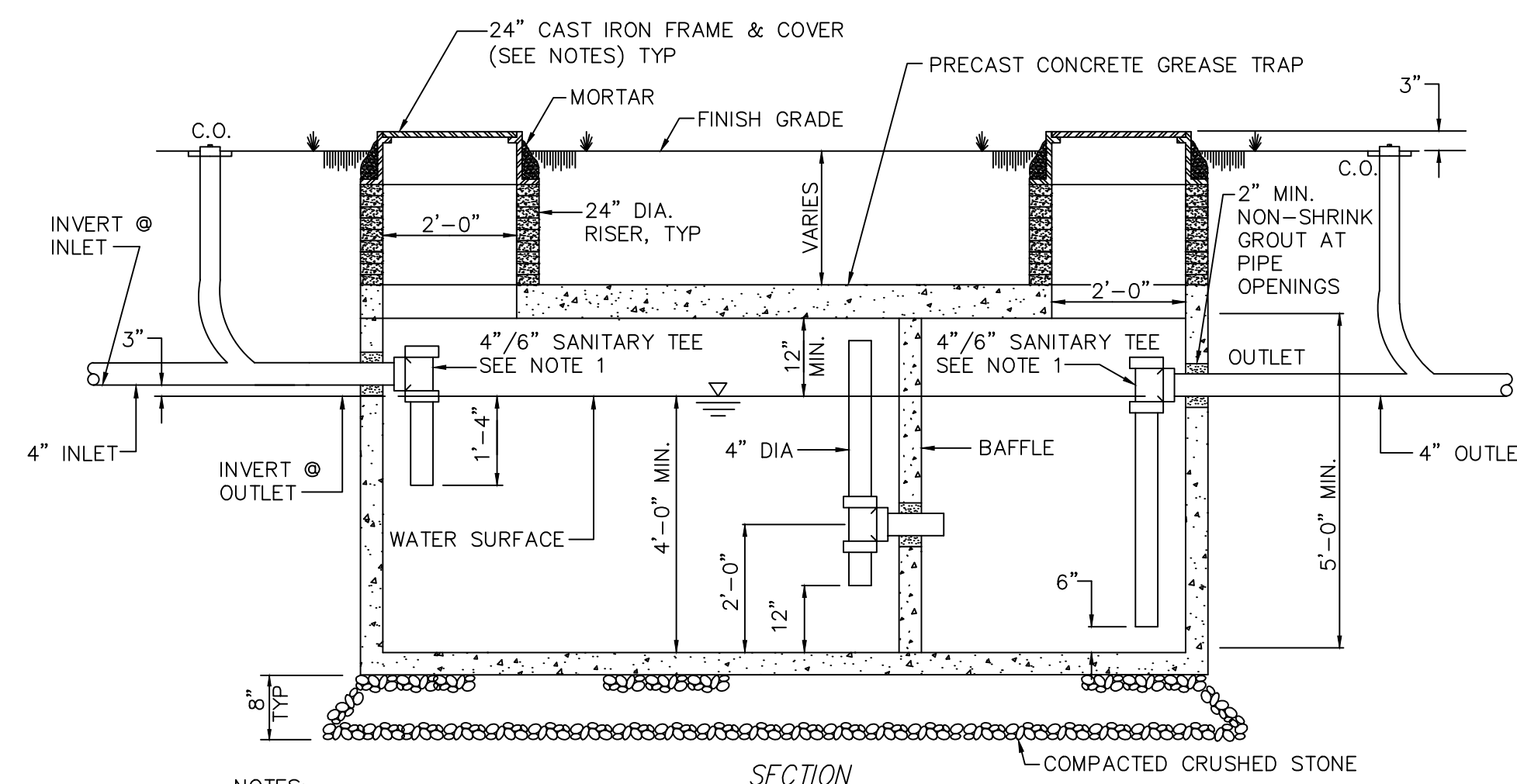

SECTION

- NOTES:
1. SANITARY INLET AND OUTLET TEE SHALL BE 4" FOR GREASE TRAP AND 6" FOR OIL/SAND SEPARATOR.
  2. MANHOLE RING & COVER SHALL BE GAS AND WATER TIGHT PROVIDING A 22" MINIMUM CLEAR OPENING.
  3. CONCRETE GRADE RINGS SHALL BE UTILIZED TO BRING COVER TO FINISHED GRADE.
  4. MINIMUM SIZE OF OIL/SAND/GREASE SEPARATORS IS 1000 GALLONS PER BRUNSWICK COUNTY POLICY. FACILITIES MAY REQUIRE LARGER TRAPS BASED ON USAGE. ENGINEER MUST SIZE AS REQUIRED.

1,000 GALLON OIL/SAND/GREASE SEPARATOR  
DETAIL S-16

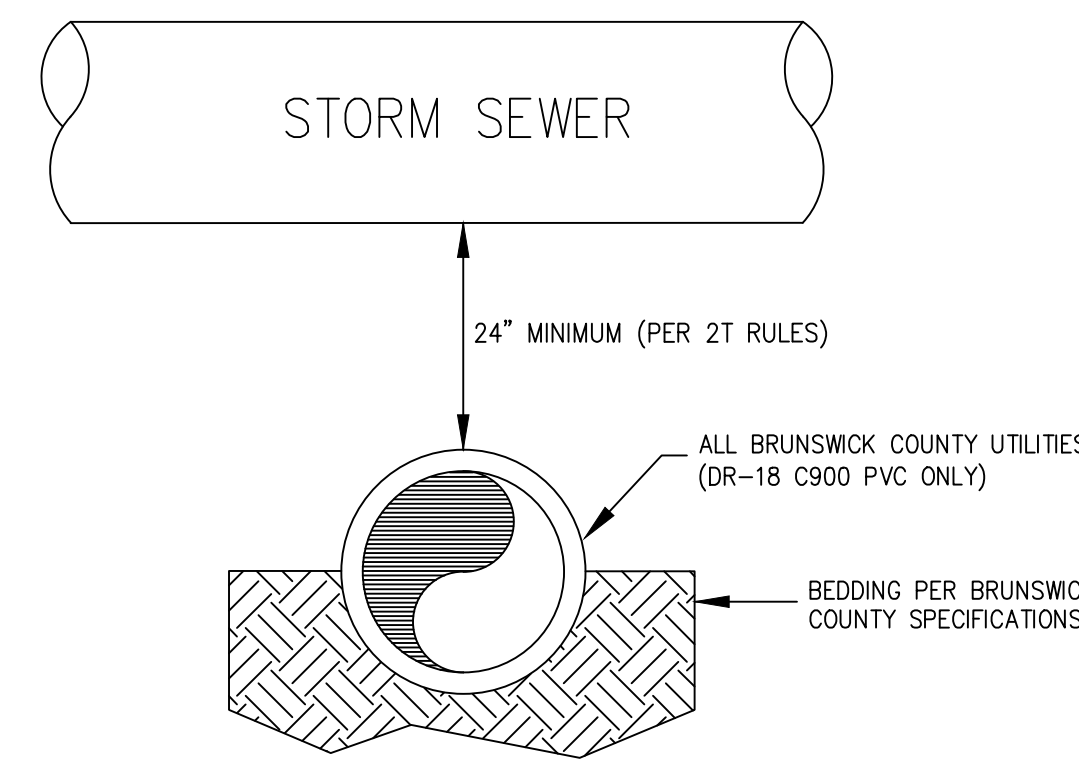

S-15A  
STANDARD CONDITION

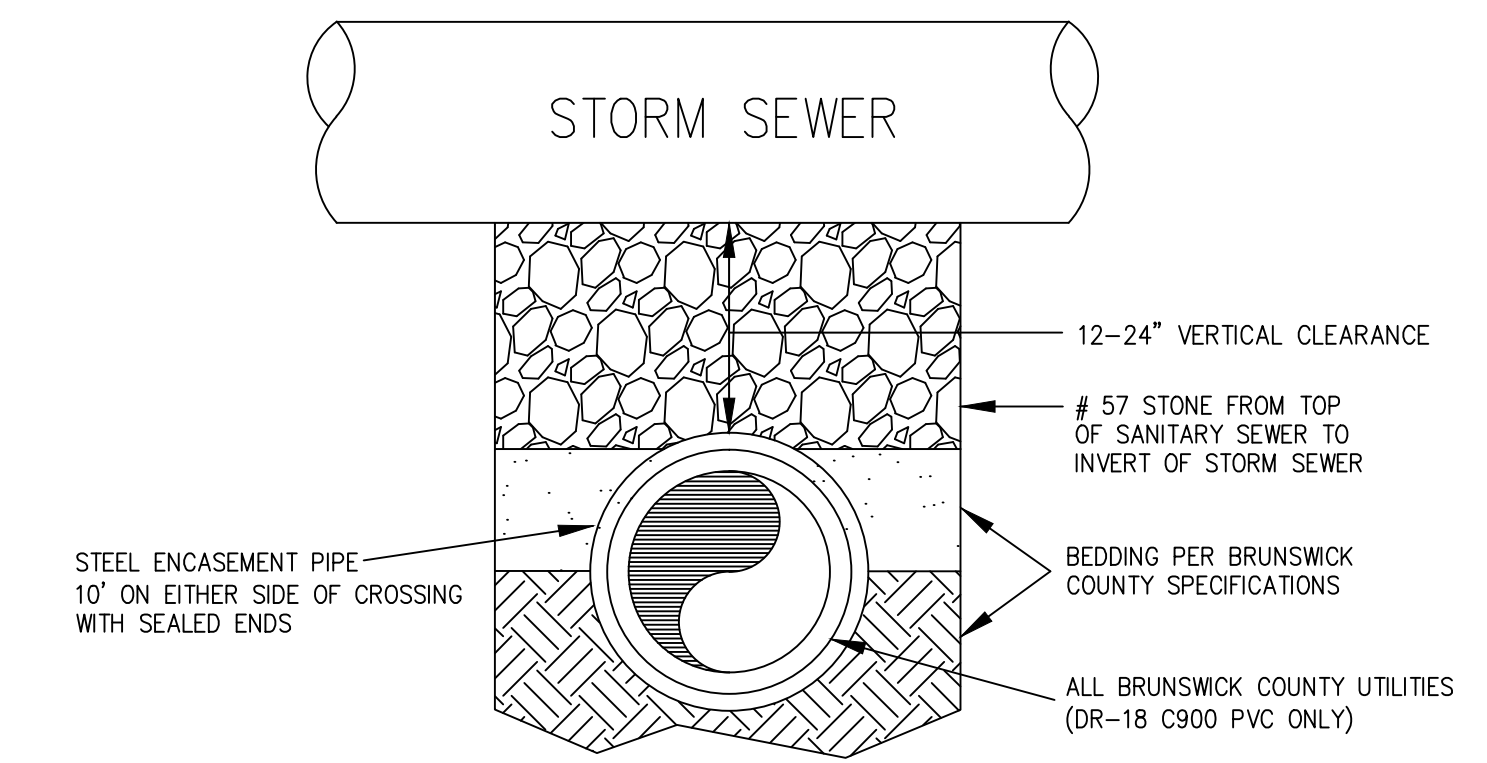

S-15B  
12-24" VERTICAL CLEARANCE

GRAVITY SEWER CROSSING BELOW STORM SEWER  
DETAIL S-15

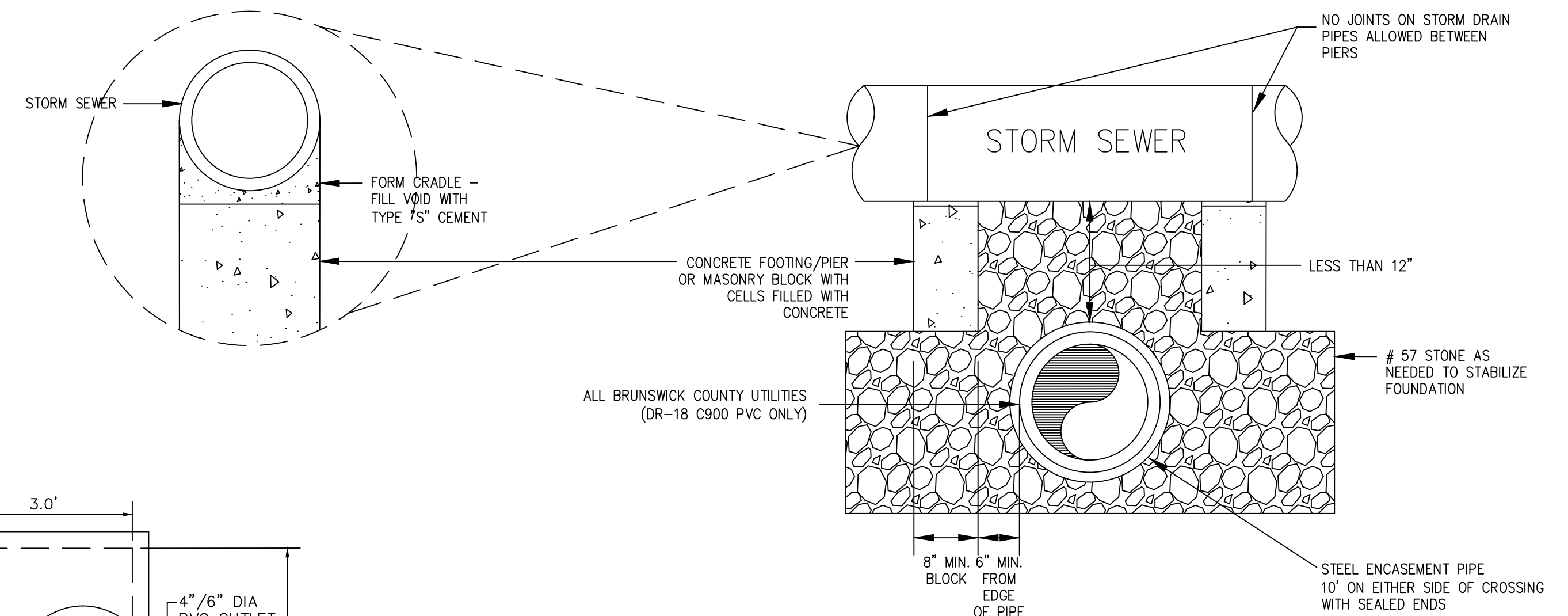

S-15C  
LESS THAN 12" VERTICAL CLEARANCE

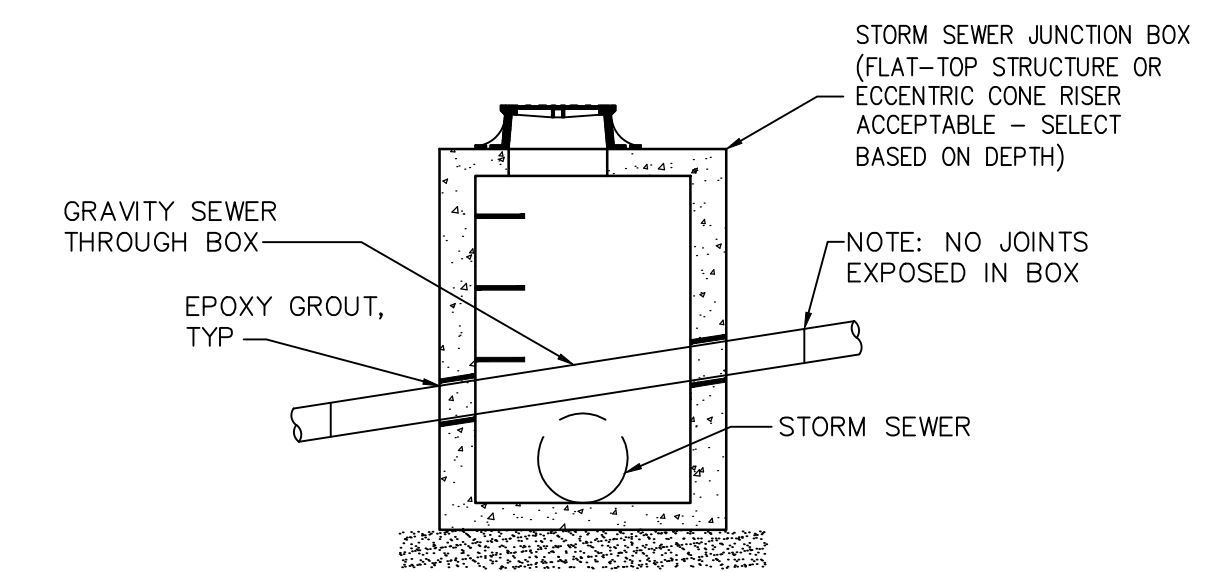

SECTION VIEW

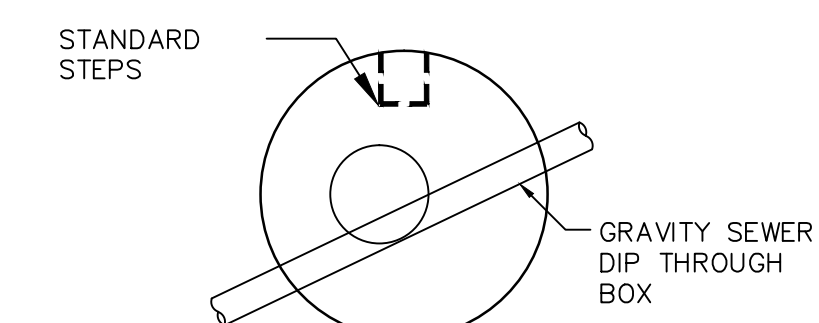

PLAN VIEW

INTERFERENCE SANITARY SEWER MANHOLE  
GRAVITY SEWER THROUGH STORM SEWER  
DETAIL S-17

Revisions

- |                        |
|------------------------|
| 1.1 - DATED 10/27/2015 |
| Mod S-15               |
| 1.2 - DATED 1/23/2019  |
| Mod S-15B, S-15C       |

COUNTY OF BRUNSWICK

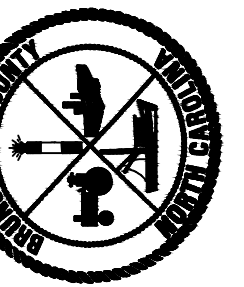

GENERAL SEWER DETAILS  
FOR  
BRUNSWICK COUNTY  
NORTH CAROLINA

Date: 07-09-12

Scale: NTS

Drawn By: JDM

Checked By: WLP